

December 2003  
 UPDATE

# How To Rout "Needle Pins" On Your Leigh Jig

 These instructions are based on the assumption that you are fully conversant with the dovetailing instructions in the Leigh Jig User Guide. Do not attempt the following procedures until you are.

## NEEDLE PINS

### Through Dovetails

The pin socket and pin size in routed dovetails can only be as narrow as the dovetail cutter profile. Here is a way to rout fine pins on the Leigh Jig and save yourself about 60% of the normal time in cutting the complete joint by hand.

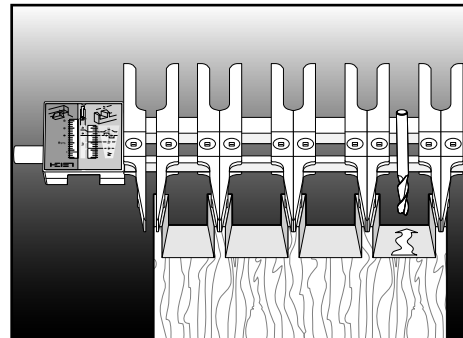
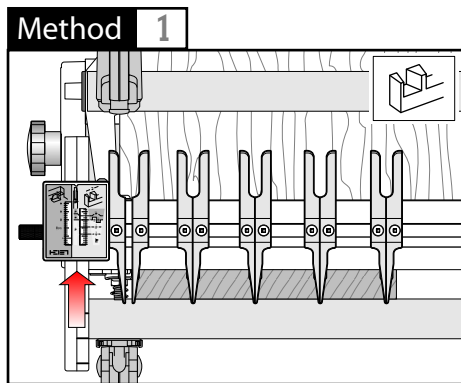

Position the finger assembly as far back as you can without the cutter rounding off the narrow part of the pin. If this doesn't produce a narrow enough pin for your liking, try the following method for really narrow pins.

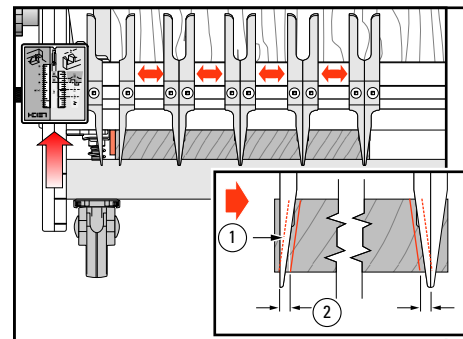
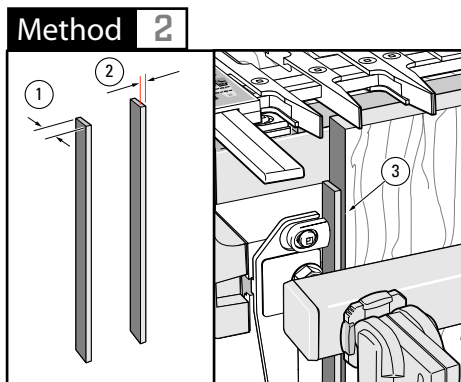

**2-1**  
 Make up two wood shims; which must be narrower than your project board thickness ①. The thickness ② will depend on the pin "neck" size you require. See table 2-7.  
 Use one shim to space the pin board away from the side stop ③.

**2-2**  
 Set the pin scale to the normal setting of the selected board thickness, see table 2-7. Position the guide fingers to the desired layout. The half pin guides are positioned to the final pin size required ①, **plus one shim thickness** ②.

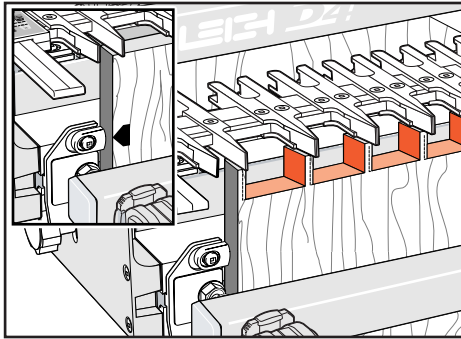

**2-3**  
Remove the strip and reposition the pin board against the side stop. Rout the pins. The right hand half pin will be the final size; the left hand half pin will be two shims wider.

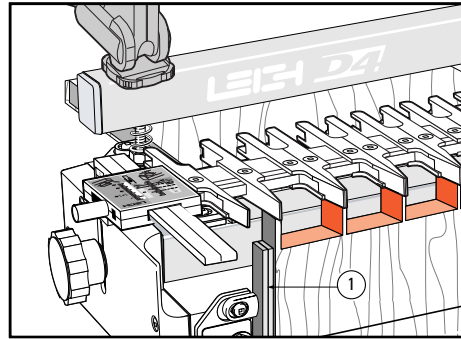

**2-4**  
Reposition the pin board with both shims between the side stop and board 1. Re-rout the exposed pin sides (i.e. the right sides if you are working at the left end of the jig).

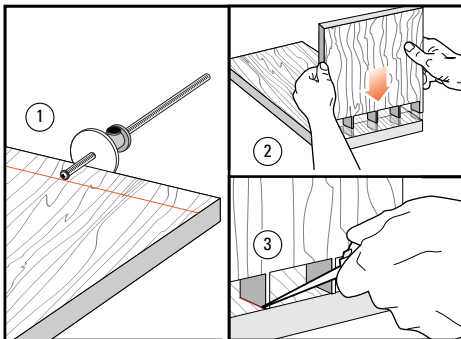

**2-5**  
Mark the required depth of cut on the tailboard with a marking gauge 1. Turn the pin board upside down and place it on top of the end edge of the tail board, the wide base of the pins on the marking gauge line 2. Use a scratch awl to mark the pin socket lines 3.

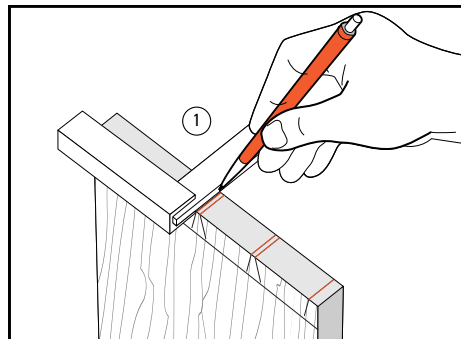

**2-6**  
Square the marks across the front edge of the board 1.

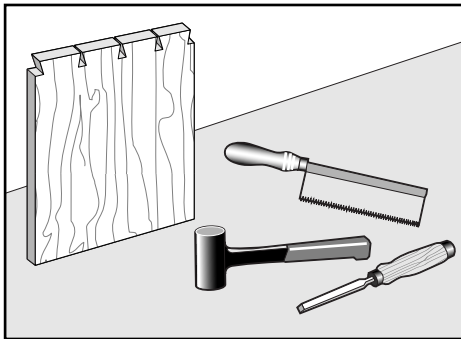

**2-6**  
Finish by sawing and chiseling the pin sockets and hand fitting in the "traditional" way. Sorry, we don't do instructions for that!

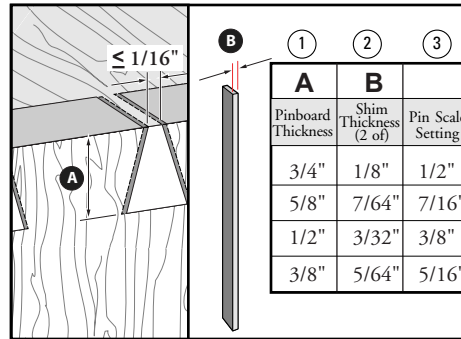

**2-7** For 1/16" "neck", look up the pin board thickness 1, find the shim thickness 2. Set the pin scale as in 3. For smaller necks, increase the shim thickness to suit. ■

## Half Blind Dovetails

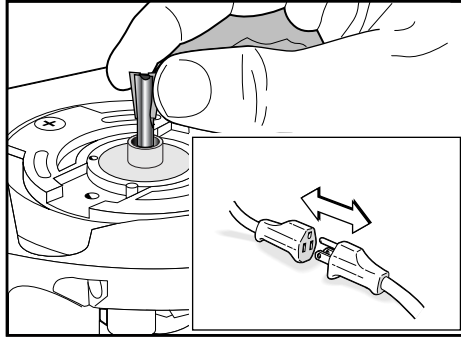

### 3-1

Use any of the Leigh half-blind cutters and 7/16" diameter guidebush.

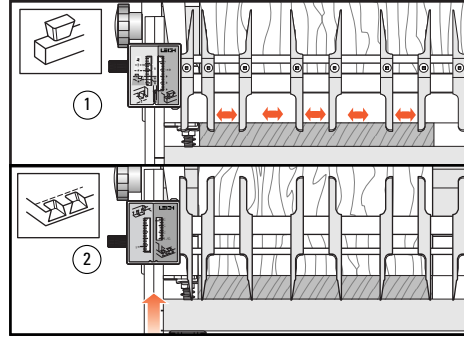

### 3-2

Instead of laying out the guide fingers in pairs, lay them out as single guides with the pin ends directly over the required pin position. Do this in the tail mode so that the finger screws are accessible ①. Then flip to the HB Pin mode ②.

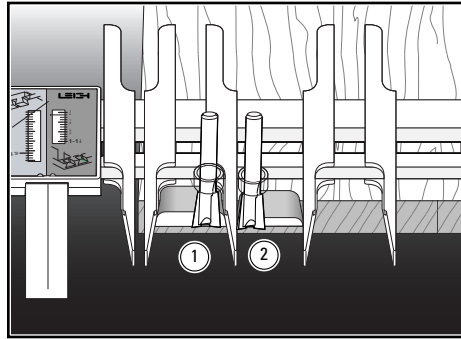

### 3-3

Rout the half-blind pins by running the guidebush not only down the normal side of the pin guide ①, but also down the back of the pin guide ②.

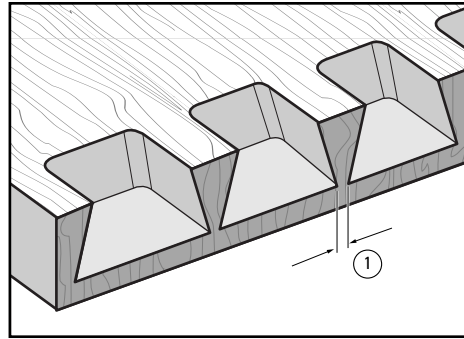

### 3-4

This will make a pin 3/16" narrower than standard, producing a pin "neck" of about 1/16" across ①. Leave the router cutter set at the same depth in the router.

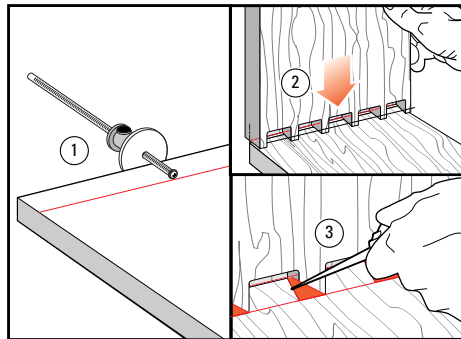

### 3-5

Mark the Depth of cut on the tailboard with a marking gauge ①. Turn the pin board upside down and place it on top of the end edge of the tailboard, the wide base of the pins on the marking gauge line ②. Use a scratch awl to mark the pin socket lines ③.

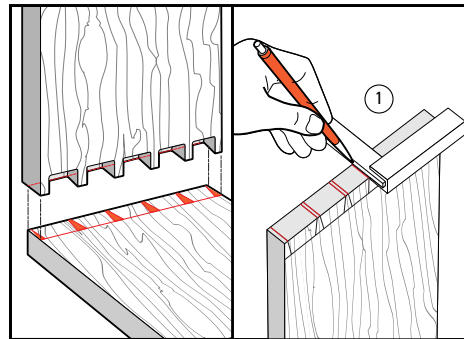

### 3-6

Square the marks across the front edge of the board ①.

## Half Blind Dovetails

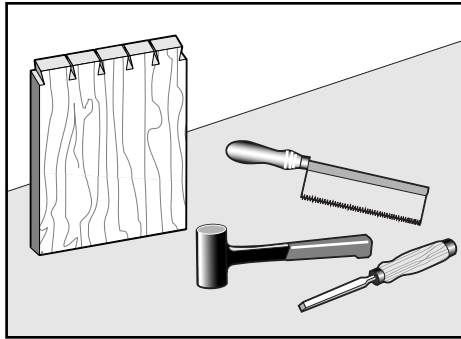
**3-7**

Saw and Chisel the pin sockets in the traditional way.

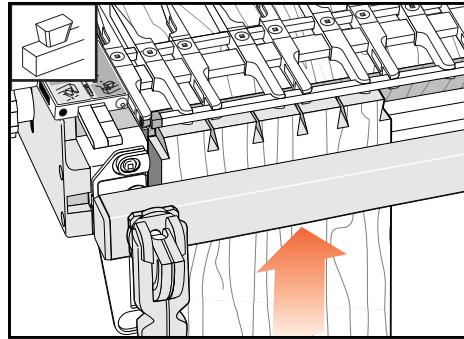
**3-8**

Mount the Tail boards back into the jig with the assembly in the tail mode, set on the tailboard thickness.

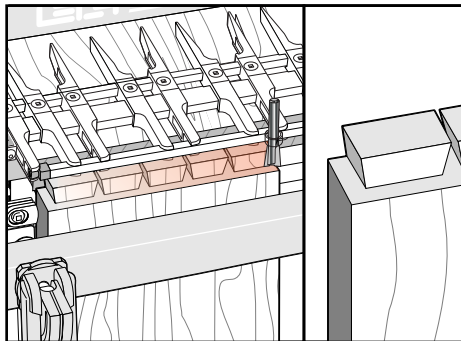
**3-9**

You left the router set to depth, so now use the cross cut bar to rout across the back of the board.

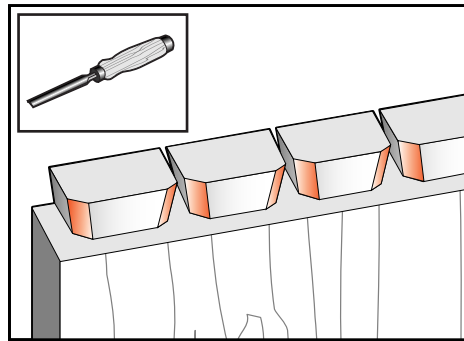
**3-10**

Chisel off the rounded tail corners. ■